







Digital Cameras for Microscopes

The Nikon Digital Sight series enhances the quality of the observation, recording, and analysis.

Four camera options covering two computing platforms

Digital Sight 100	Digital Sight 1000	Digital Sight 10	Digital Sight 50M
			
→ P.3	→ P.4	→ P.5	→ P.5
6.5 megapixel	2.0 megapixel	23.9 megapixel	60.0 megapixel
Color	Color	Color/Monochrome	Monochrome
C-mount	C-mount	F-mount	F-mount
Frame rate* 60 fps (1600×900)	Frame rate 30 fps (1920×1080)	Frame rate* 9 fps (6000×3984) 55 fps (2000×1328)	Frame rate* 6 fps (9552×6336) 225.9 fps (640×480)
Max recordable pixels* 2944×2208	Max recordable pixels 1920×1080	Max recordable pixels 6000×3984	Max recordable pixels 9552×6336

Using a desktop PC/tablet PC

Imaging software
NIS-Elements
Advanced Solutions for your Imaging World
LE



→ P.8

Using a desktop PC

Imaging software
NIS-Elements
Advanced Solutions for your Imaging World
D Ar Br F



Only NIS-Elements F is compatible with Digital Sight 1000 → P.6

Digital Sight 100

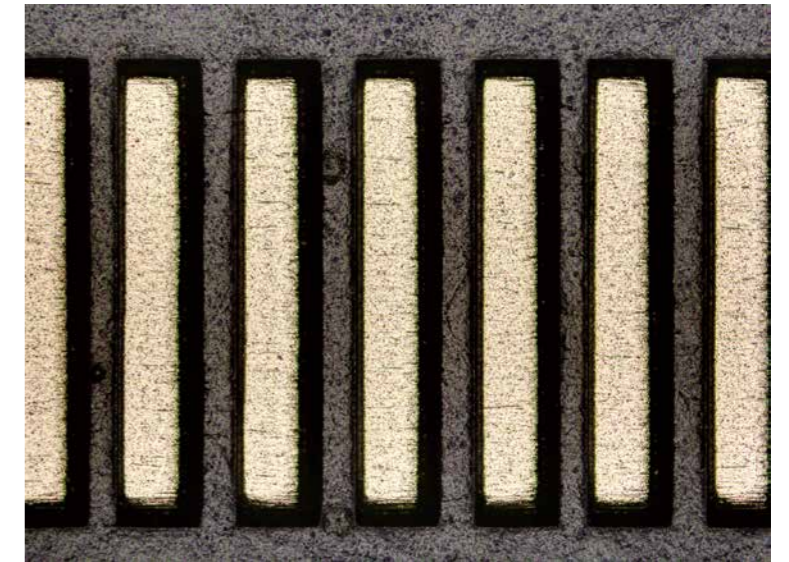

Printed circuit board (Objective: TU Plan Fluor BD 5x brightfield)

High-definition / High-level color reproducibility / High frame rate

Used with industrial microscopes (FN 16), the Digital Sight 100 delivers 6.5-megapixel resolution (2944 x 2208 pixels), ensuring clear capture of fine structural details and rich color information.



Compatible with multiple device interfaces

Operators can utilize USB 3.2, HDMI, Wi-Fi, and/or Ethernet to share information taken with the Digital Sight 100. PC-free observation is available via HDMI monitor connection. Workloads can be reduced with easy operations by using the camera with Nikon's NIS-Elements LE software, as well as the NIS-Elements D/Ar/Br.

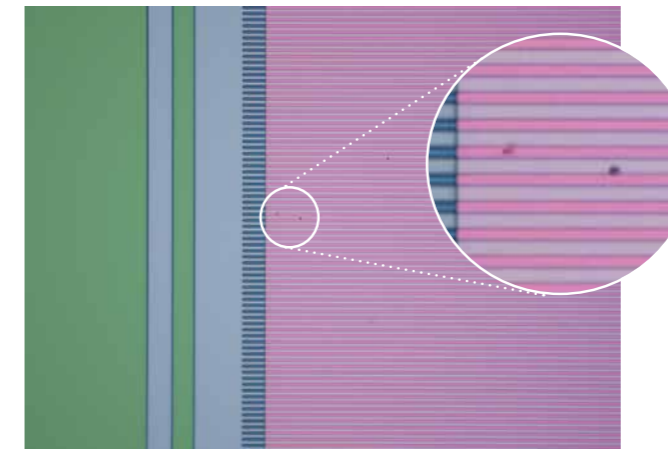

Semiconductor (IC wafer) (Objective: TU Plan Fluor BD 50x brightfield)

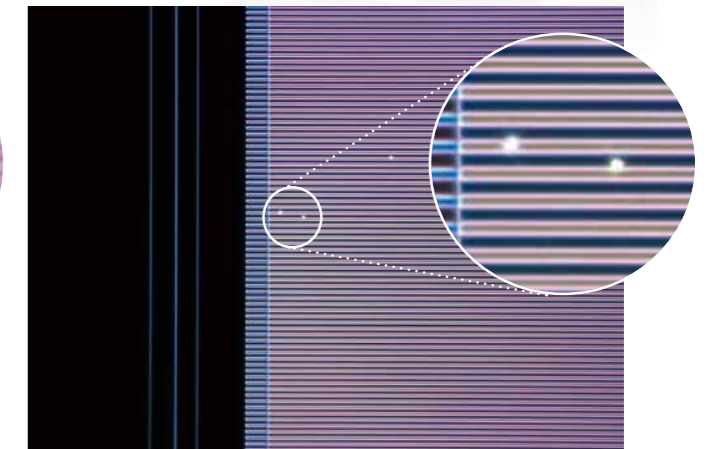

Semiconductor (IC wafer) (Objective: TU Plan Fluor BD 50x darkfield)

*Digital Sight 100 (standalone) delivers 17.7-megapixel resolution (4864 x 3648 pixels) and has maximum frame rate of 15 fps.

Digital Sight 1000

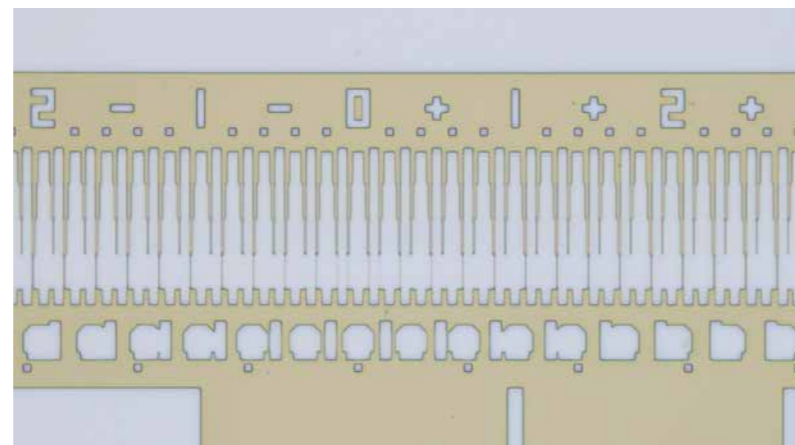

Semiconductor (IC wafer)
(Objective: TU Plan Fluor 20x on Nikon ECLIPSE microscope)

Low cost, Full HD Camera

Equipped with a 2 megapixel CMOS image sensor, it can display, capture, and save full HD microscope images of 1920 x 1080 pixels at 30 frames/second.

Easy operation on HDMI display

By connecting the microscope to a camera and HDMI monitor, movie and still images can be created, captured and data can be saved to an SD card. No PC connection is required to display scales and reticles, as well as to conduct simple measurements.

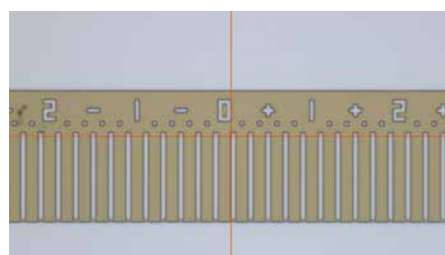
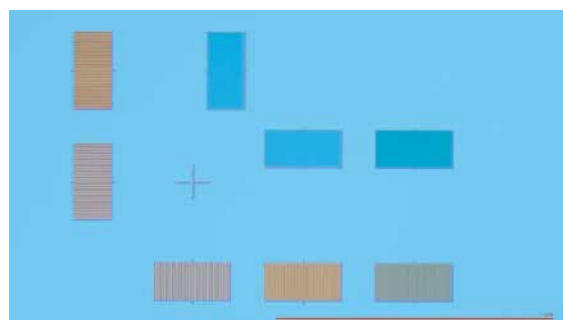

Cross Line (Line Display)

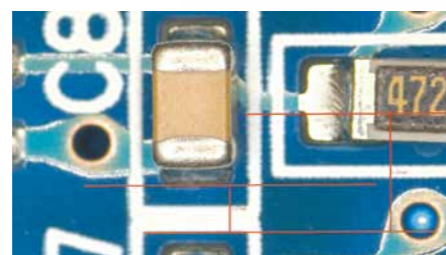

Perpendicular Distance Measurement

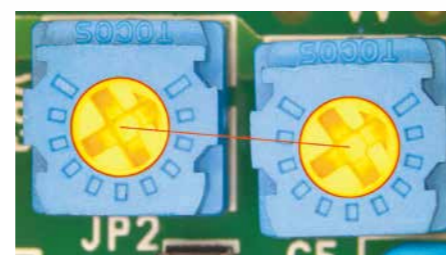

Circle Distance Measurement

Main Features

- Image Comparison
- Scale Bar Display
- Rectangle Display
- Perpendicular Distance Measurement
- Circle Distance Measurement
- Reticle Display
- Coordinate Display
- Circle Display
- Parallel Line Measurement
- Angle Measurement
- Scale Reticle Display
- Line Display
- Polygon Display
- Concentric Circles Measurement
- Saving Measurement Result
- Measurement Calibration
- Freehand Line Display

Digital Sight 10



High-definition observation

Digital Sight 10 enables unprecedented 6K ultra-high definition, capturing microscopic images at up to 6000 x 3984 pixels (23.9 megapixels).

Color and Monochrome shooting are both possible with one camera unit During manual operation

Color mode

Inserting the color filter optimizes the image from 400 to 680 nm in color live display and capture modes



Monochrome mode

Inserting the IR filter in place of the color filter now extends the IR imaging range from 400 to 850 nm in both live and capture modes.

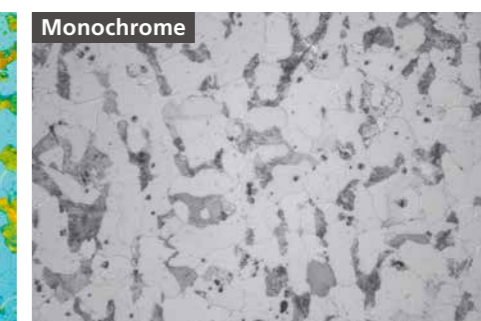
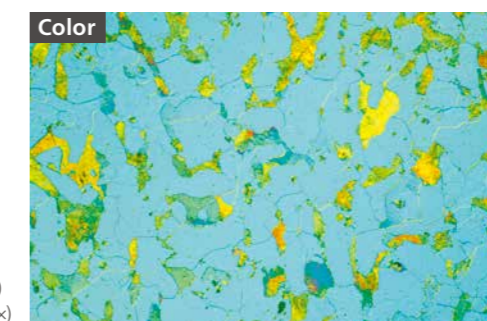

Metallic structure (aluminum)
(Objective: TU Plan Fluor 50x)

High-speed display

Digital Sight 10 is able to output a standard or a user definable Region of Interest (ROI) directly from the sensor area.

(Position and size limits on ROI are present in the camera, but images are cropped using the SDK to provide an unrestricted ROI to the user.)

Electric switching function

During electronic operation (using the 1x electronic adapter)

Easy switching between color and monochrome modes using the imaging software is possible by a motorized, hands-free process.

*A 1x electronic adapter and a separate PC equipped with specialized imaging software, NIS-Elements, are required for automated filter change operation.

Digital Sight 50M



9K ultra-high resolution

The improved Digital Sight 50M boasts 3.8 times the number of pixels and 2.5 times the resolution of previous models. Even when using a low-magnification, high-NA objective lens, it fully demonstrates optical capabilities.

Low noise

Acquires dim fluorescent signals with ultra-low noise

Both 6e- read noise coupled with a large full-well capacity and 1.0e-/p/s dark current allow the acquisition of 14bit fluorescence images with very little noise.

High sensitivity

Detects even faint fluorescent signals

The Digital Sight 50M achieves quantum efficiency of 85%. Even faint fluorescence signals can be captured by the pixels on account of the broad 3.76 μm pixel pitch and high quantum efficiency.

Numerous image acquisition modes

Adjustable balance between quality and speed

There are three operation modes, making it possible to select the required speed and quality. Maximum frame rate of 225.9 fps for high-speed photography.

NIS-Elements D/Ar/Br/F offer image acquisition, analysis, visualization and data sharing tools. The software has a fully customizable user interface and can be seamlessly integrated with Nikon microscopes and cameras. The NIS-Elements platform features various packages and software modules to meet the needs of even the most challenging applications.

HDR (High Dynamic Range) image acquisition

Ar Option D Br

HDR creates an image with appropriate brightness in both the dark and bright regions in a sample by combining multiple images acquired with different exposure settings. It is also possible to create HDR image using multiple captured images.

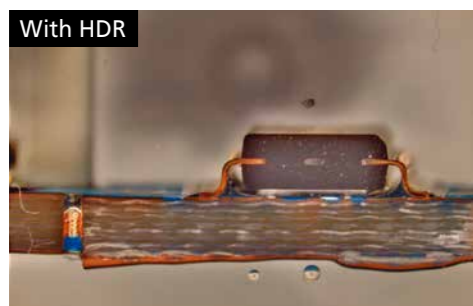
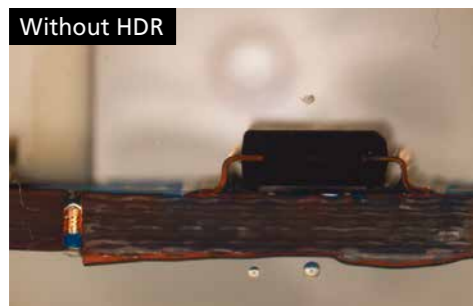

EDF (Extended Depth of Focus)

Option Ar Br D

Creates a single, all-in-focus image from images of differing focus. Such images can now be created by simply turning the focus knob.

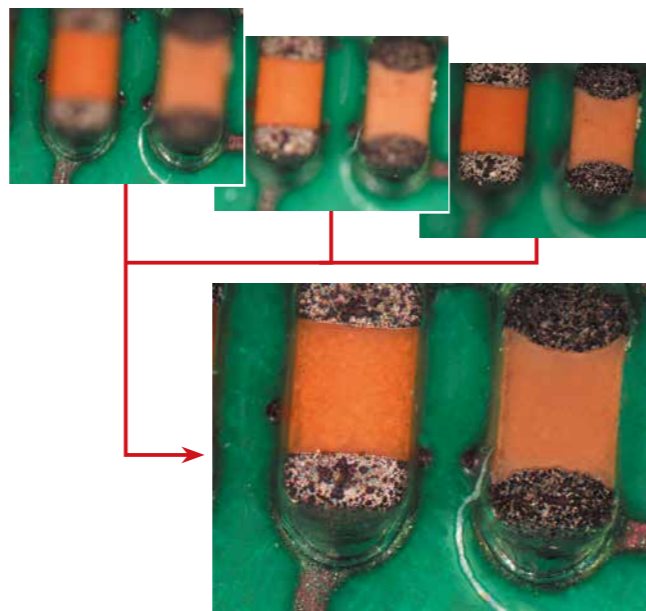

Selects the in-focus area and produces one all-in-focus image

Auto measurement (Object Counting)

Ar Br Option D

Performs binarization on images using previously set thresholds to measure the number, area, brightness, etc. of identified objects.

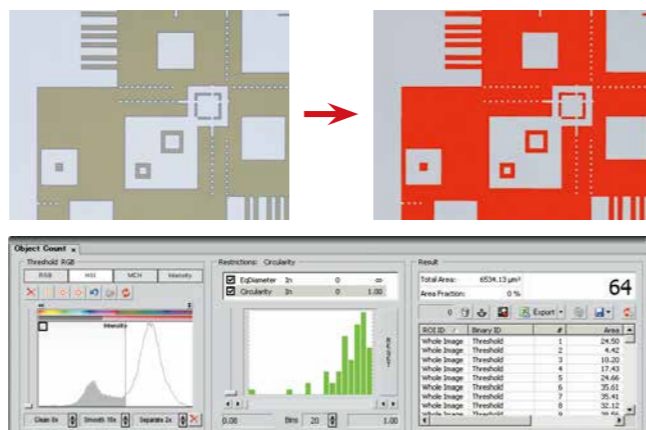

Manual measurement and image annotation

D Ar Br

Manual Measurement allows easy measurement of length and area by drawing lines or an object directly on the image. The results can be attached to the image, and also exported as text or to an Excel spreadsheet.



Grain size analysis

Option Ar Br D

Detects and measures grains in one and two phase samples according to JIS G0551:2020, ASTM E112-13:2021/E1382-97:2023, ISO 643:2019 and GB/T 6394:2017 standards.

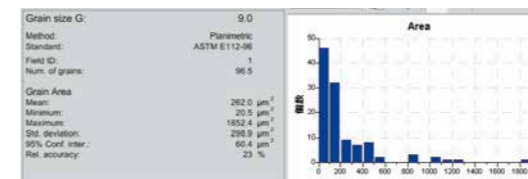
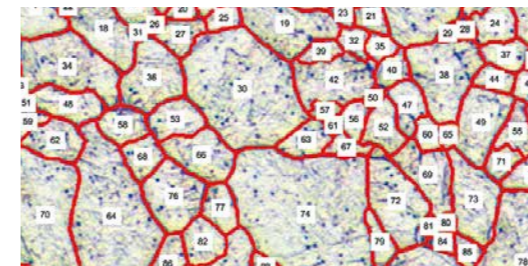

Cast iron analysis

Option Ar Br D

Detects, measures and classifies graphite content as well as ferrite content in graphite-corrected samples according to JIS G5502-JIS:2022/G5502-ISO:2022, ASTM A247-06:2019 and ISO 945-1:2019 standards.

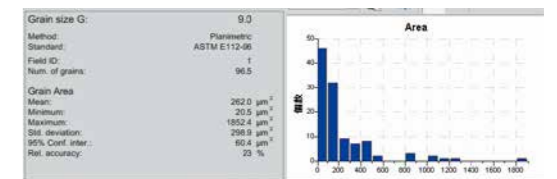
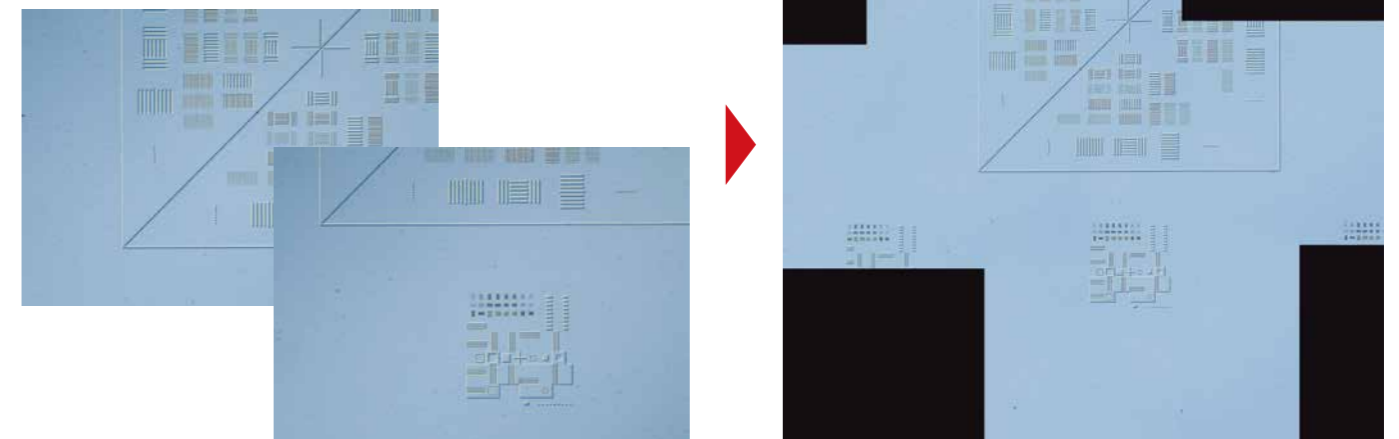

Image stitching (Large Image)

Option Ar Br D

Stitches together images acquired from multiple fields of view. This can occur from images as they are acquired or from previously captured images.



Measuring Software

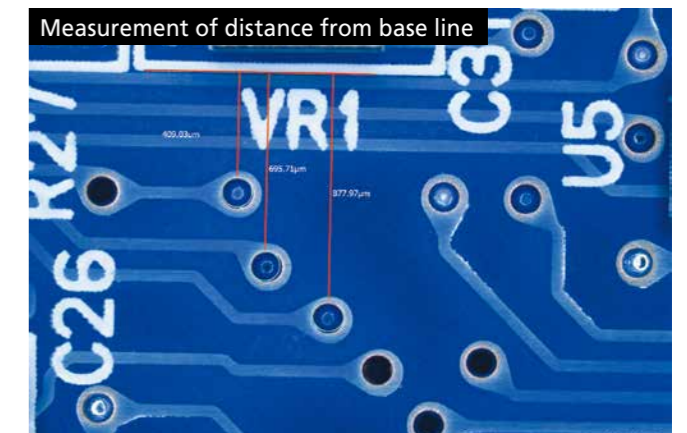
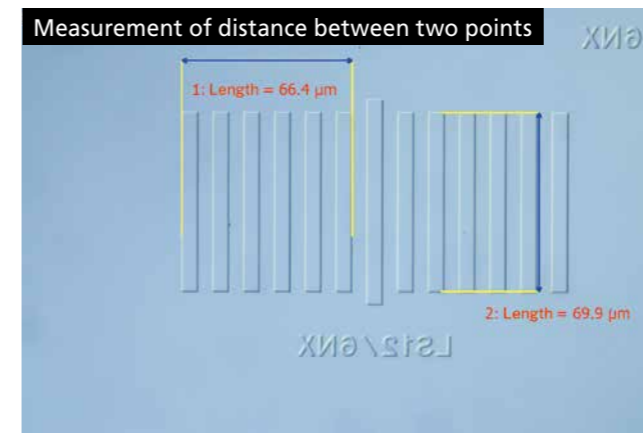

NIS-Elements LE is a free software that allows intuitive control of microscope cameras from the PC. Supports Wi-Fi connectivity when used with the Digital Sight 100.

*For information about compatible tablet PCs, contact Nikon

User Interface for naturally simple operation

Displays various menus for image capture, saving, display, measurement and annotations using intuitive icons. It also supports touch screen operation.

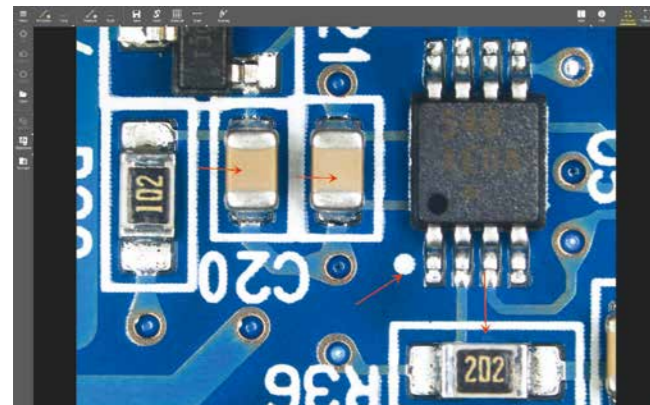

A wide variety of tools

Enables the conducting of simple measurements on images, with input of lines and comments. These can also be written onto and saved with the image, and measurement data can be output.

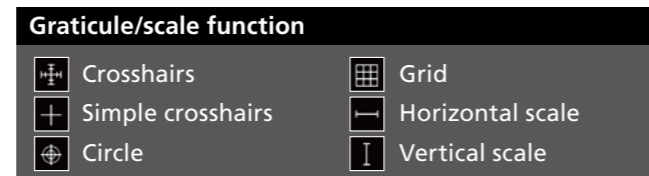
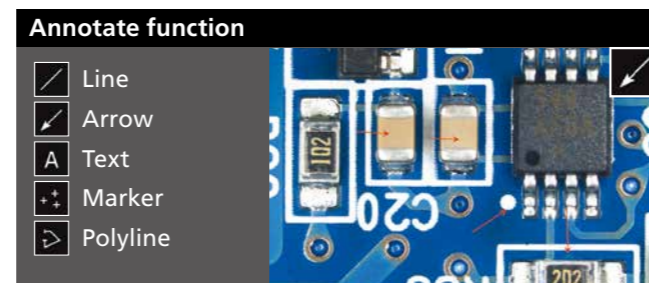
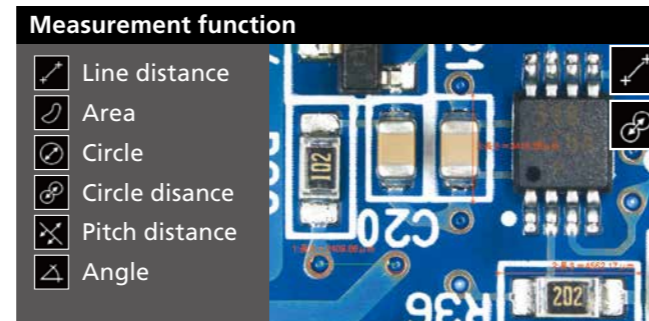

Scene mode

Ten camera setting patterns for optimal color reproduction and contrast for each microscope light source, observation method and type of sample, as well as custom settings, can be selected.

Industrial Scene Mode

- Wafer/IC
- Metal
- Circuit board
- Flat Panel Display

Dimensions (Unit: mm)

Digital Sight 1000

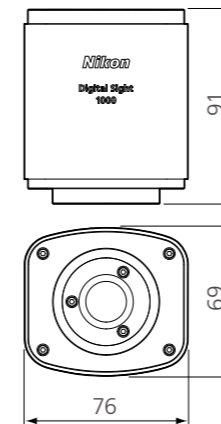

Weight: approx. 450 g

Digital Sight 100

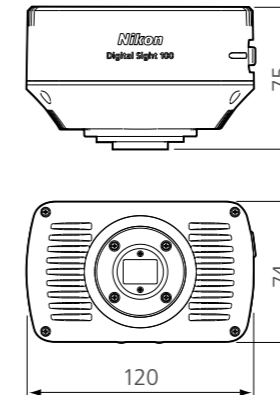

Weight: approx. 600 g

Digital Sight 10

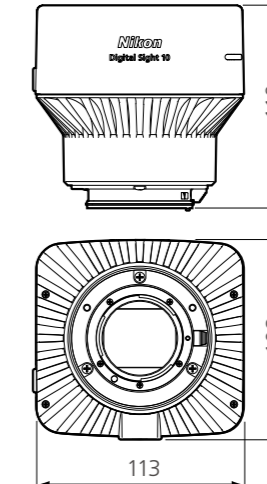

Weight: approx. 1,100 g

Digital Sight 50M

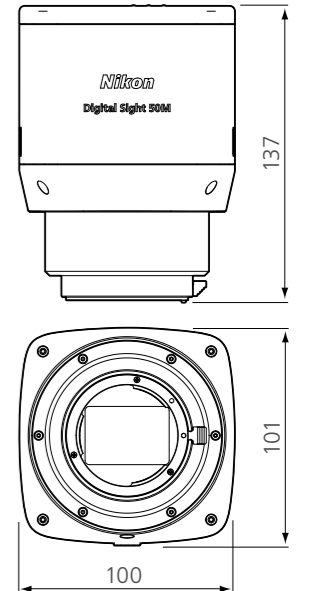

Weight: approx. 1,300 g

System Diagram

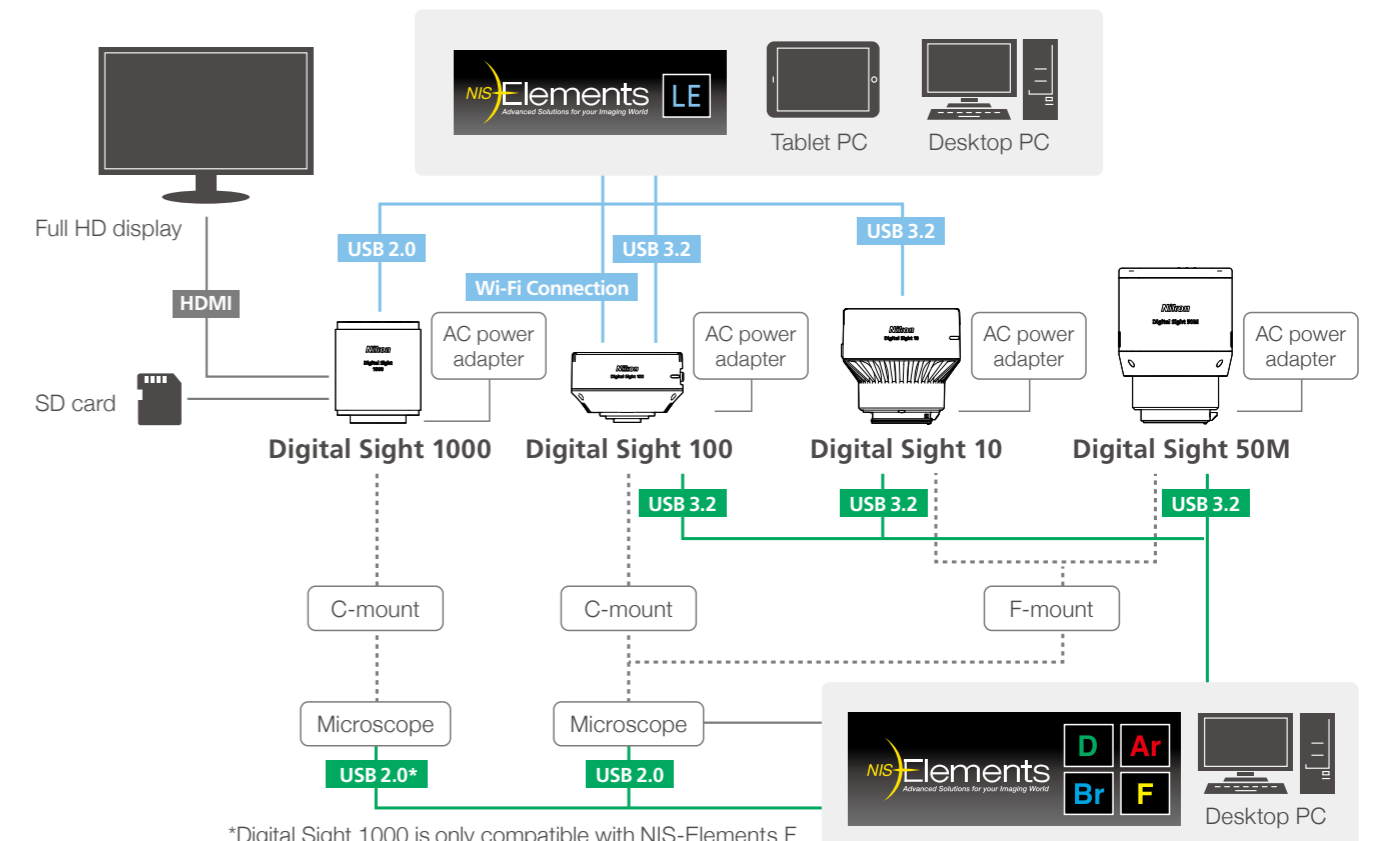

*Digital Sight 1000 is only compatible with NIS-Elements F

Specifications

Model name	Digital Sight 1000	Digital Sight 100	Digital Sight 10	Digital Sight 50M
Image sensor	1/2.8 inch Color CMOS image sensor	1 inch Color CMOS image sensor	Nikon FX-format Color/ Monochrome CMOS image sensor	Nikon FX-format Monochrome CMOS image sensor
Recordable pixels	1920 × 1080 pixels	2944 × 2208 pixels	6000 × 3984 pixels	9552 × 6336 pixels
Lens mount	C-mount		F-mount	
Cooling method	—			Electronic cooling
Quantum efficiency	—			85 %
Full well Capacity	—			45000e- (typ.)
Readout noise	—			6e-
Dark current	—			1.0e-/p/s (Ta=25°C)(typ.)
Live display mode* (maximum fps)	1920 × 1080 pixels: 30 fps	All pixels (4:3) 2944 × 2208 pixels: 30 fps All pixels (16:9) 3200 × 1800 pixels: 30 fps 2x2 Pixels Average 1600 × 900 pixels: 60 fps 2x2 Pixels Average (when using Wi-Fi) 1600 × 900 pixels: 60 fps	All pixels (6000 × 3984): 9 fps FullHD 3x3 pixels average (2000x1328): 55 fps	All pixels (9552 × 6336): 6 fps@8 bit, 1.9 fps@16 bit 3 × 3 pixels average @ 8 bit (ROI 640 × 480): 225.9 fps***
Exposure time	1 m sec–10 sec	100 μsec–10 sec	100 μsec–120 sec	150 μsec–120 sec
Photometry mode	Average photometry 1920 × 1080 pixels (all area)	Average photometry: Average intensity within the photometry area Peak photometry: Maximum intensity within the photometry area		
Exposure control	Automatic exposure, Manual exposure	One-time automatic exposure: Exposure time is adjusted automatically for one-time within the optimum range for the camera Continuous automatic exposure: Automatic exposure adjustment is performed continuously to keep the exposure within the camera Manual exposure: Exposure time and gain settings are made manually		
Exposure correction	Available	Average metering: ±1EV Step:1/6EV (some restrictions according to tone) Peak hold metering: -1 EV ~ ±0 EV		Average metering: -1 EV ~ +1/2 EV Peak hold metering: -1 EV ~ ±0 EV
Interface	USB2.0 (connect with PC or USB mouse) × 1, HDMI × 1, SD card slot x1**	USBPort1 (Device): USB3.2 Gen2x1 (USB2.0 not supported) USBPort2 (Host): USB3.2 Gen1x1 HDMI1.4b MSC communication	USB3.2GEN1,2 (connect with PC) × 1 External trigger × 1	USB3.2GEN1 (connect with PC) × 1 External trigger × 1
Power supply	AC100-240V 50Hz/60Hz			
Power consumption	3 W	7 W	18 W	27 W
Operating environment	0-40°C, 60% RH max. (without condensation)			

*Maximum frame rate depends on exposure time. **Both SD and SDHC memory cards are compatible with the Digital Sight 1000 camera.

***When using NIS-Elements, 16-bit mode can be selected for 1x1 and 2x2 digital binning, and 12-bit mode can be selected for 2x2, 3x3, 4x4 and 6x6. 8bit mode can be selected in all image size modes.

The Wi-Fi functionality of Digital Sight 100 is provided by external Wi-Fi dongles (sold separately) available in each country and region. In principle, Wi-Fi dongles should be purchased from local distributors or in-country representative, ensuring compliance with local laws and regulations in your region. We do not bundle them with the product nor export/import them across borders. Using dongles certified for other countries may violate local laws and regulations. Always use products that are legally sold in your local market. Warranty and support for Wi-Fi dongles are subject to the terms and conditions of your local distributors or in-country representative.

Specifications and equipment are subject to change without any notice or obligation on the part of the manufacturer. December 2025 ©2004-2025 NIKON CORPORATION

Microsoft and Windows are registered trademarks of Microsoft Corporation in the United States and other countries. Company and product names listed in this brochure are trademarks or registered trademarks of each company. N.B. Export of the products* in this brochure is controlled under the Japanese Foreign Exchange and Foreign Trade Law. Appropriate export procedures shall be required in case of export from Japan.

*Products: Hardware and its technical information (including software)

⚠ WARNING TO ENSURE CORRECT USAGE, READ THE CORRESPONDING MANUALS CAREFULLY BEFORE USING THE EQUIPMENT.



NIKON CORPORATION

1-5-20, Nishioji, Shinagawa-ku, Tokyo 140-8601, Japan

Tel: +81 3 6743 5742

<https://industry.nikon.com/>

ISO 14001 Certified
for NIKON CORPORATION

ISO 9001 Certified
for NIKON CORPORATION
Industrial Solutions Business Unit

NIKON METROLOGY EUROPE NV

Interleuvenlaan 86, 3001 Leuven, Belgium

Tel: +32 16 74 01 01

Sales.NM@nikon.com

NIKON METROLOGY UK LTD.

UNITED KINGDOM Tel: +44 1332 811 349

Sales.UK.NM@nikon.com

NIKON METROLOGY SARL

FRANCE Tel: +33 1-60 86 09 76

Sales.France.NM@nikon.com

NIKON METROLOGY GMBH

GERMANY Tel: +49 211 4544 6951

Sales.Germany.NM@nikon.com

NIKON METROLOGY, LLC

12701 Grand River Road, Brighton, MI 48116 U.S.A.

Tel: +1 810 220 4360

Sales.NM-US@nikon.com

NIKON METROLOGY - MEXICO

Sales.NM-US@nikon.com

NIKON PRECISION (SHANGHAI) CO., LTD.

CHINA Tel: +86 21 6841 2050 (Shanghai)

CHINA Tel: +86 10 5831 2028 (Beijing branch)

CHINA Tel: +86 20 3882 0551 (Guangzhou branch)

Web.Nis@nikon.com

NIKON INSTRUMENTS KOREA CO., LTD.

KOREA Tel: +82 2 6288 1900

NIK.Sales@nikon.com

NIKON SINGAPORE PTE LTD.

SINGAPORE Tel: +65 6559 3651

NSG.Industrial-sales@nikon.com

PT. NIKON INDONESIA

INDONESIA Tel: +62 213 873 5005

PTN.Instruments@nikon.com

NIKON SALES (THAILAND) CO., LTD.

THAILAND Tel: +66 2633 5100

NST.Inst@nikon.com



EXCEL
TECHNOLOGIES, INC.

www.exceltechnologies.com

99 Phoenix Avenue, Enfield, CT USA 06082-1258
Tel: (860) 741-3435 | Fax: (860) 745-7212